

Helideck Monitoring System (HMS)

- Meets Norwegian helicopter operators' standards
- Complies with the CAA, CAA-N, UKOOA/OGUK, Canadian and UK helicopter operators' guidelines
- Includes clear displays and reports of helideck conditions for flight planning (local network or Internet)
- Integrates to existing sensors with the option to add new sensors for waves, currents, cloud, visibility and other parameters
- Includes remote diagnostics and software upgrades to keep up to date with regulations
- Provides offline data reporting and summary statistics available for incidents, operational downtime, wind roses, etc
- Audible and visual alarm warnings are available
- Optional data outputs to third party systems (e.g. DP, DVR, ICSS)
- 24/7 Offshore System Support



Helideck Monitoring

Safety and cost are keywords in all offshore helicopter operations; these become all the more critical when assessing the criteria for safe landing. For example with long flights to and from floating production or drilling units.

In such cases reliable information on weather and helideck motion needs to be supplied at the outset of and continually during a flight to give maximum opportunity for the flight to be completed safely and efficiently. Combining additional meteorological and oceanographic sensors to the system will ensure clear, accurate, direct and relevant measurements of the prevailing conditions to all who require them. These measurements can be viewed at the heliport or used to compare environmental trends with forecasts to improve planning accuracy.



Helideck Display Screen Shot

Fugro engineers have worked for many years in helping to provide useful information for helicopter operators. The Fugro software and system design has proven to be ideal in integrating differing inputs from a wide range of sources and managing data to suit a vast range of applications.

Software Display

Clear displays show and provide easy access to the data that are needed for operational decision making and pre-flight planning. They allow the vessel motion, wind and wave trends to be examined for expected conditions on arrival and thus avoid unnecessary flights. Any adverse weather working policy can be included to the display, to help maximise the operation window for offshore operations.

Measured Parameters

- Heave, Pitch, Roll, Surge, Sway, Yaw
- Heave Rate, Heave Acceleration
- Helideck Inclination
- Motion and Wind Severity Index
- Barometric Pressure (QNH, QFE)
- Wind Speed and Direction
- Air Temperature and Relative Humidity

Optional Parameters

- Sea Water Temperature
- Waves (directional/non-directional)
- Sea Currents
- Visibility and Cloud Height
- Precipitation
- Lightning Monitoring

Helideck Motion

Helideck motion can become particularly significant at the bow or stern of a ship, where the vertical heave motion is added to the pitch that is further amplified by the length of the vessel. It's impact is most severe when a vessel has significantly changing "dynamic" properties due to heavy load transfers or metocean conditions.

LAN / WAN Network

Data displays are available for examination locally on the data acquisition computer as well as remotely through direct browsing with Internet Explorer across Local and Wide Area Networks. They can also be viewed through the Fugro GEOS Internet display service that provide crew and other onshore support teams' direct access to important information.

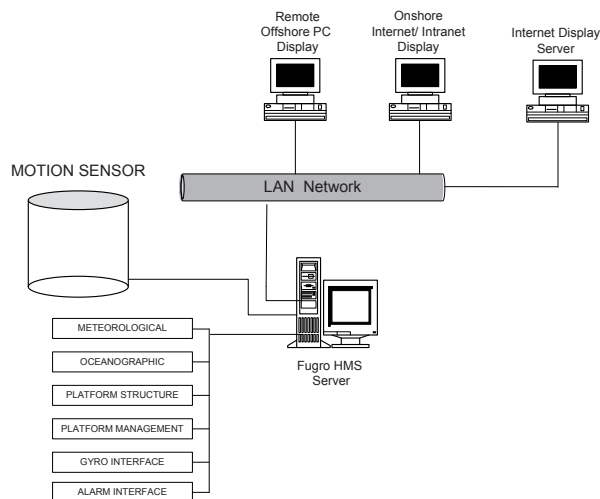

Example of a Helideck Monitoring System layout

Regulation and Certification

The software is designed to meet the latest regulations and certification standards required by helideck monitoring systems for offshore FPSOs and floating vessels. These include specific "Standard Measuring Equipment for Helideck Monitoring System (HMS) and Weather Data guidelines" issued by CHC Helicopter Service and the Norsk Helikopter Service. Fugro was the first commercial company to be certified by the Norwegian Civil Aviation Authorities (CAA-N) to conform to the regulations stated under BSL D 5-1 and BSL G 7-1 for the supply of HMS. The systems meet the CAP437 Civil Aviation Authority (CAA) required for HMS and can also be ATEX certified under EN13980.

Standards

The Fugro HMS calculates final meteorological condition parameters based on standards and requirements given by the World Meteorological Organization (WMO) and the Norwegian Meteorological Institute (DNMI) regarding meteorological equipment for use at airports and landing areas for helicopters, both offshore and onshore.



Manual / Auto Metar Input Screen

The Fugro HMS also includes optional outputs to all typical standards such as the Norwegian Standard (NORSOK), DF22 data output to DNMI, automatic, semi-automatic or manual METARS, MANMARS and other Internet distribution options including Fugro's own XML transmitting format for onshore Internet display hosting.

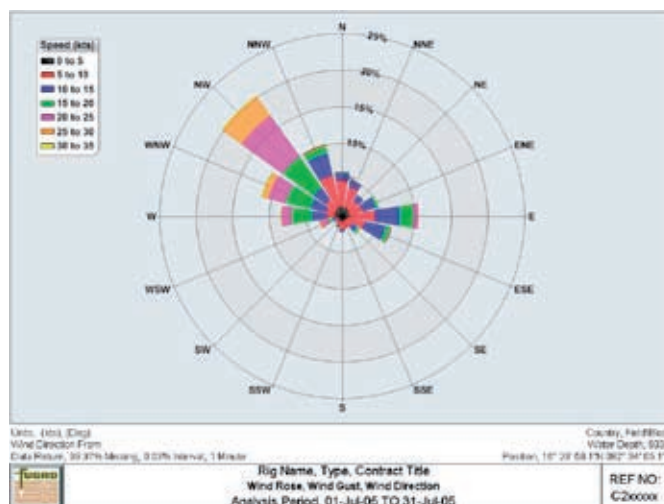

References

The HMS Software has been proven operationally under extreme conditions for over a decade in the North Sea. The software has since been installed in over 400 sites around the world meeting stringent regulations and requirements in differing countries and regions such as Norway, Canada and Brazil.

For more information on these services or for offshore system support, contact your local Fugro office in Norway, UK, Singapore, Kuala Lumpur or Houston listed below.



L1HS061016

Fugro GEOS Ltd, Wallingford, UK
Tel: +44 870 402 1500
Email: uk@geos.com

Fugro GEOS, Structural Monitoring, Glasgow, UK
Tel: +44 141 774 8828
Email: fsm@geos.com

Fugro GEOS, Abu Dhabi, UAE
Tel: +971 2 554 5101
Email: gulfmet@geos-uae.com

Fugro GEOS Pte Ltd, Singapore
Tel: +65 6543 4404
Email: singapore@geos.com

Fugro GEOS, Perth, Australia
Tel: +61 8 6477 4400
Email: perth@geos.com

Fugro GEOS Sdn Bhd, KL, Malaysia
Tel: +60 3 2164 6210
Email: meto@geos.com.my

Fugro GEOS Inc, Houston, USA
Tel: +1 713 346 3600
Email: geosusa@fugro.com

Fugro OCEANOR AS, Trondheim, Norway
Tel: +47 7354 5200
Email: trondheim@oceanor.com

Fugro OCEANOR AS, Sandnes, Norway
Tel: +47 5163 4330
Email: sandnes@oceanor.com